



# ONE RIVER POINT

BY RAFAEL VIÑOLY

## EAST TOWER

# RESIDENCE E3

LINE 06 ON FLOORS: 10-50

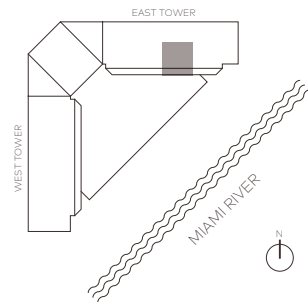

2 Bedrooms  
2.5 Bathrooms

Interior: 1,278ft<sup>2</sup> / 119m<sup>2</sup>  
Terrace: 475ft<sup>2</sup> / 44m<sup>2</sup>  
Total: 1,753ft<sup>2</sup> / 163m<sup>2</sup>



For inquiries, please call 305-809-7566 or visit: [oneriverpoint.com](http://oneriverpoint.com)



This is not intended to be an offer to sell, or solicitation to buy, condominium units to residents of any jurisdiction where such offer or solicitation cannot be made or are otherwise prohibited by law, and your eligibility for purchase will depend upon your state of residency. This offering is made only by the prospectus for the condominium and no statement should be relied upon if not made in the prospectus. The information provided, including pricing, is solely for informational purposes, and is subject to change without notice.

**ORAL REPRESENTATIONS CANNOT BE RELIED UPON AS CORRECTLY STATING THE REPRESENTATIONS OF THE DEVELOPER. FOR CORRECT REPRESENTATIONS, MAKE REFERENCE TO THIS BROCHURE AND TO THE DOCUMENTS REQUIRED BY SECTION 718.503, FLORIDA STATUTES, TO BE FURNISHED BY A DEVELOPER TO A BUYER OR LESSEE.**

**APPLICABLE TO NEW YORK RESIDENTS:** This advertisement is not an offering. It is a solicitation of interest in the advertised property. No offering of the advertised units can be made and no deposits can be accepted, or reservations, binding or non-binding, can be made until an offering plan is filed with the New York State Department of Law. This advertisement is made pursuant to Cooperative Policy Statement No. 1, issued by the New York State Department of Law. CP16-0027, Sponsor: KAR Miami MRP LLC, 24 SW 4th Street, Miami, Florida 33130.

Stated dimensions are measured to the exterior boundaries of the exterior walls and the centerline of interior demising walls and in fact vary from the dimensions that would be determined by using the description and definition of the "Unit" set forth in the Declaration (which generally only includes the interior airspace between the perimeter walls and excludes interior structural components). Additionally, measurements of rooms set forth on any floor plan are generally taken at the greatest points of each given room (as if the room were a perfect rectangle), without regard for any cutouts. Accordingly, the area of the actual room will typically be smaller than the product obtained by multiplying the stated length times width. All dimensions are approximate, and all floor plans and development plans are subject to change.

This Condominium is being developed by MIAMI RIVER PROJECT, LLC a Delaware limited liability company ("Developer"), which has consulted with the various Design Team and Development Team members ("Team Members"). Developer has a limited right to use the trademarked names and logos of the Team Members. Any and all statements, disclosures and/or representations shall be deemed made by Developer and not by any of the Team Members and you agree to look solely to Developer (and not to any Team Members, including, without limitation, Rafael Vinoly Architects or Kar Miami MRP LLC and/or any of their affiliates) with respect to any and all matters relating to the marketing and/or development of the Condominium and with respect to the sales of units in the Condominium.

Plans and elevations are artist's renderings and may contain options which are not standard on all models. All dimensions are approximate and subject to change. At Miami River Project, LLC, a Delaware limited liability company's discretion and should not be relied upon. Additionally, all fixtures and items of finish and decoration depicted are for display only and are not to be included with the unit. Consult the sales office for a description of those features which are to be included in the units.

The items depicted and described herein are intended to illustrate the type of fixtures and/or items of finish that are anticipated to be used in various areas within the development. Developer may, in its sole discretion, make changes and/or elect to make omissions. Additionally, Developer has the right to substitute or change materials and/or colors, equipment, appliances, fixtures, finishes landscaping, lighting and all other matters of construction or detail. Even if no changes are made, certain items are subject to size and color variations, grain and quality variations, and may vary in accordance with price, availability and changes by manufacturer from those specified. Certain colors described and/or as shown herein, including, but not limited to, stone, marble, granite, cabinetry, carpeting and wood stain, will weather and fade and may not be duplicated precisely. All exposed wood, tile and stone surfaces are subject to variations in color, unevenness, and non-structural changes and cracks, and the Developer will not be responsible for any repair, replacement, or damages due to any of such causes.

